

Inverter / Charger Accessory

for Steca Solarix PLI 5000-48 and Solarix PLI 2400-24



3-Phase / Parallel Kit

Installation and operating instructions



Table of Contents

About this Manual	3
Purpose.....	3
Scope.....	3
Keywords and Symbols	3
General Safety Instructions	3
Introduction	4
Installation	4
Package Contents.....	4
Parallel Board Installation.....	5
Solarix PLI 5000-48	5
Solarix PLI 2400-24	8
Mounting the Inverters	9
Minimum Distances for Installation of Inverters.....	9
Wiring Considerations.....	10
AC Wiring	10
PV Module Wiring.....	10
Fuses or Circuit Breakers	10
Battery Capacity.....	11
Wiring Examples	11
Parallel Operation of Two Inverters on Single Phase	12
Parallel Operation of Three Inverters on a Single Phase.....	12
Parallel Operation of Four Inverters on a Single Phase.....	13
Parallel Operation of Five Inverters on a Single Phase.....	14
Parallel Operation of Six Inverters on a Single Phase	14
Parallel Operation of Seven Inverters on a Single Phase	14
Parallel Operation of Eight Inverters on a Single Phase	15
Parallel Operation of Nine Inverters on a Single Phase	15
3-Phase Operation of Three Inverters (1 + 1 + 1)	16
3-Phase Operation of Four Inverters (2 + 1 + 1).....	17
3-Phase Operation of Five Inverters (3 + 1 + 1).....	18
3-Phase Operation of Five Inverters (2 + 2 + 1).....	19
3-Phase Operation of Six Inverters (3 + 2 + 1)	20
3-Phase Operation of Six Inverters (4 + 1 + 1)	21
3-Phase Operation of Six Inverters (2 + 2 + 2)	22
3-Phase Operation of Seven Inverters (3 + 3 + 1).....	22
3-Phase Operation of Seven Inverters (4 + 2 + 1).....	23
3-Phase Operation of Seven Inverters (3 + 2 + 2).....	23
3-Phase Operation of Seven Inverters (5 + 1 + 1).....	23
3-Phase Operation of Eight Inverters (4 + 2 + 2).....	24
3-Phase Operation of Eight Inverters (5 + 2 + 1).....	24
3-Phase Operation of Eight Inverters (3 + 3 + 2).....	24
3-Phase Operation of Eight Inverters (4 + 3 + 1).....	24
3-Phase Operation of Nine Inverters (3 + 3 + 3).....	25

3-Phase Operation of Nine Inverters (4 + 3 + 2).....	25
3-Phase Operation of Nine Inverters (4 + 4 + 1).....	26
3-Phase Operation of Nine Inverters (5 + 2 + 2).....	26
3-Phase Operation of Nine Inverters (5 + 3 + 1).....	26
Configuration.....	27
Commissioning	29
Parallel Inverters on a Single Phase	29
Inverters in a 3-phase Configuration	30
Fault Reference Codes	33
Troubleshooting.....	33
Guarantee Conditions	35
Exclusion of Liability.....	35
Contact.....	35

About this Manual

Purpose

This manual describes the assembly, installation, operation and troubleshooting of this 3-phase / parallel extension kit (referred throughout this manual as “kit”). The purpose of the kit is to enable Steca Solarix PLI 5000-48 or Solarix PLI 2400-24 inverter / chargers (referred throughout this manual as “inverter” or “unit”) to be interconnected so that the AC output can be parallelised or installed as a 3-phase system with 120° phase-shift between more than one Solarix PLI. **Only inverters of the same model may be interconnected, it is not permitted to mix Solarix PLI 5000-48 with Solarix PLI 2400-24 models! One kit is required per interconnected inverter.** Please read this manual carefully before installation and operation. Keep this manual for future reference.

Note: The inverter transfer time between AC input / grid mode and inverter / off-grid mode may increase from 10 ms (UPS mode for single inverter) up to a maximum of 50 ms by interconnecting multiple inverters.

Scope

This manual provides safety and installation guidelines as well as information on wiring and operation.

Keywords and Symbols

These keywords are used in this manual with the following meanings:

Keyword	Description
DANGER	Immediate danger of death or serious bodily injury
WARNING	Possible danger of death or serious bodily injury
CAUTION	Possible danger of light or medium bodily injury or damage to equipment



This symbol indicates a warning or danger, pay particular attention to these sections.

General Safety Instructions



WARNING: This chapter contains important safety and operating instructions. Read and keep this manual for future reference.

1. This document is part of the product.
2. **CAUTION** Only qualified professionals may perform the installation work described in this manual.
3. Before using the unit, read all instructions and cautionary markings on the inverter / charger Solarix PLI (especially the Solarix PLI installation and operating instructions) and this manual.
4. **DANGER** Be very cautious when working with metal tools near batteries. A risk exists in short-circuiting batteries or other electrical parts, potentially causing an explosion or fire. Use only insulated tools.
5. **WARNING** Ensure that all cables, particularly the AC input, AC output, photovoltaic (PV) and battery cables of the Solarix PLI are seated properly in their contacts and tightened correctly. No cable insulation may protrude into the cable terminals. Any materials other than the cable / cable lug / ring terminal inserted into the terminals could cause excessive heating, damage and / or fire.
6. Any use of this product aside from its intended purpose as described in this manual could lead to damage and/or serious personal injury. Opening any part of the device apart from the bottom cover (described in this manual) will void the warranty and can lead to damage or serious personal injury.

Introduction

CAUTION: This kit must be purchased separately from your local dealer and is not included with the Solarix PLI inverter. One kit is absolutely required for parallel or 3-phase operation for each interconnected Solarix PLI. Failure to install the kit correctly in multi-inverter systems is likely to cause significant damage to the inverters and other equipment. This kit may only be installed by qualified personnel and by following these instructions.

The Solarix PLI 5000-48 or 2400-24 inverters can be used in parallel with two different operation modes.

1. Parallel operation in single phase with up to 9 inverter units. The supported maximum output power is 45 kW / 45 kVA (Solarix PLI 5000-48) or 21.6 kW / 27 kVA (Solarix PLI 2400-24).
2. A maximum of 9 inverter units may work together to support three-phase AC loads, with a maximum of seven 7 on one phase. The supported maximum total output power is as in point 1.

Installation

Package Contents

Before installation, please inspect the kit. Be sure that nothing inside the package is damaged. Included items:

- 1 x Parallel board

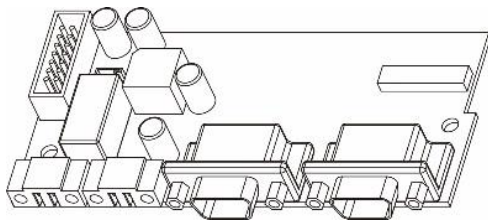

Solarix PLI 5000-48 version

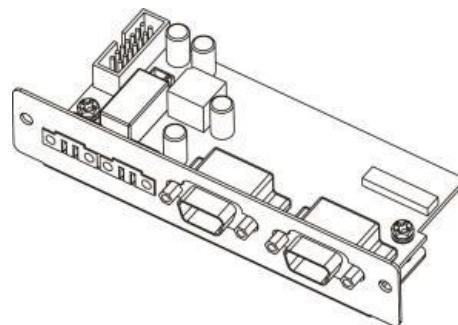

Solarix PLI 2400-24 version

- 1 x Parallel communication cable

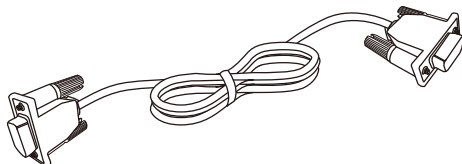

- 1 x Current sharing cable



Parallel Board Installation



DANGER: Before proceeding and installing this kit make sure the inverter is turned off and completely disconnected from all other external equipment: AC output, AC input, PV input, battery terminals and signal contact must all be disconnected. Failure to do so may lead to damage and / or serious injury.



WARNING: Handle open electronics such as the parallel board and communication board mentioned in the further steps with care, they can be damaged by electrostatic discharge (ESD). Be sure to ground yourself to discharge any electrostatic energy that may have built up in your body before proceeding.

Solarix PLI 5000-48

1. Before the kit can be installed, please take off bottom cover by removing the two screws shown in *Fig. 1* and pulling the cover off toward the bottom of the inverter to expose the terminals.

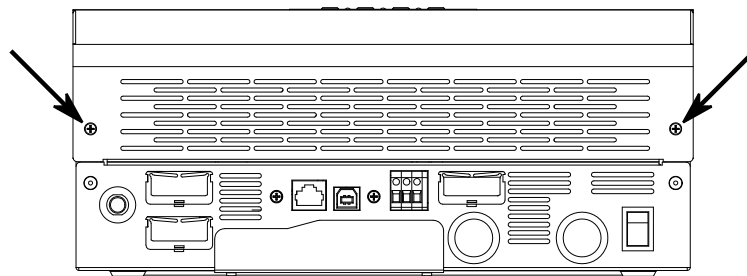

Figure 1: Screw location on bottom cover

2. Undo the three cable connectors (one 6-Pin and two 2-Pin) of the communication board as shown in *Fig. 2*. Make sure to mark them beforehand for a correct re-assembly later. The communication board is pre-assembled on every Solarix PLI inverter.

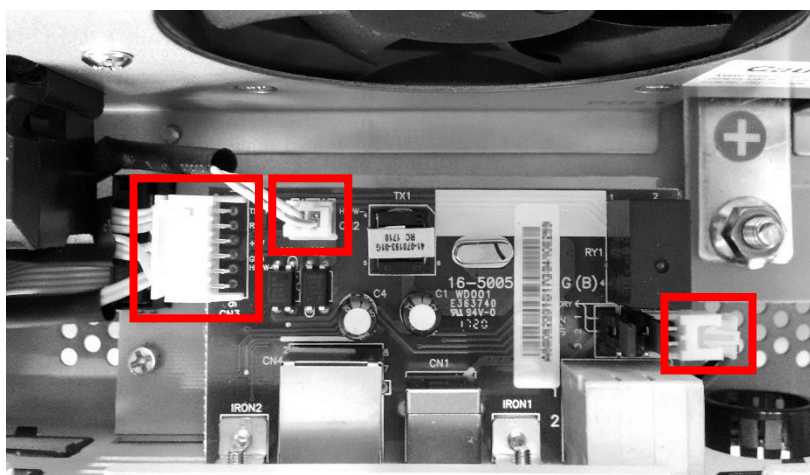

Figure 2: Remove connectors on communication board

3. Remove the communication board by removing the two screws on the bottom of the inverter as shown in *Fig. 3*, and then sliding out the communication board toward the top. These screws will be required later.

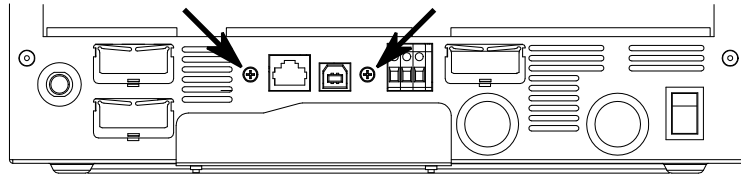

Figure 3: Screw location of communication card

4. Undo the two screws and washers of the beige board as shown in Fig. 4. They will be required later. Do not remove the board yet as it is still connected to two cables.



Figure 4: Remove screws on beige board

5. Undo the two cable connectors (14-Pin and 2-Pin) from the beige dummy board as shown in Fig. 5. Make sure to mark them beforehand for a correct re-assembly later.

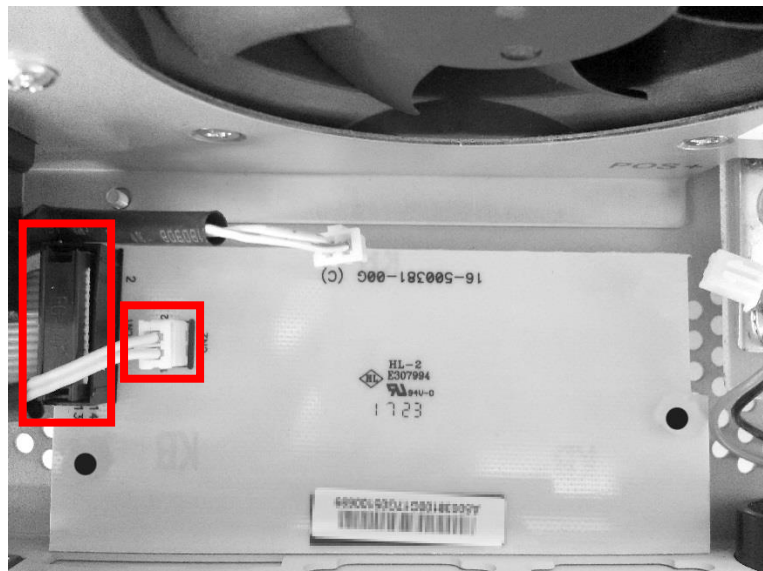

Figure 5: Remove connectors on beige dummy board

6. Remove the beige board by sliding it out toward the top of the inverter. The beige dummy board is no longer required and will be replaced by the parallel board later.
7. Remove the two screws shown in Fig. 6, which attach the metal parallel connector cover to the inverter. These screws are no longer required.

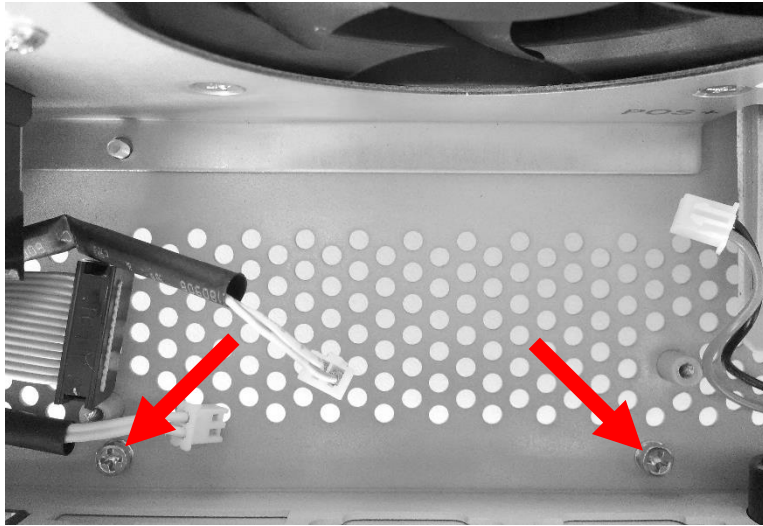

Figure 6: Remove screws from parallel connector cover

8. Remove the parallel connector cover, it is no longer required.
9. Take the parallel board from this kit and insert the 14-Pin and 2-Pin connectors (originally removed from the beige board in step 5) into the parallel board.
10. Fasten the parallel board where the beige board was originally installed using the two screws and washers from step 4. When finished, the parallel board will sit in the same place as the beige board was before removal, connected to the same connectors and fastened with the same screws. The connectors of the parallel card must match the cut-outs of the metal casing of the inverter as shown in Fig. 7.
11. Carefully re-fit the 3 connectors back onto the communication board, the reverse of step 2. The communication board must be connected to the same cables as before disassembly.
12. Screw the communication board back into the inverter, the reverse of step 3. Use the screws removed in step 3. The bottom of the inverter should now have the appearance of Fig. 7.

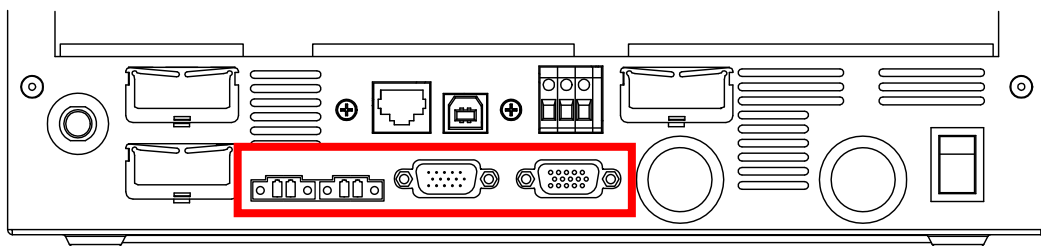

Figure 7: Bottom view of inverter with installed parallel card

13. Re-assemble the bottom cover as in Fig. 8, the reverse of step 1. You have now completed the installation of the parallel board into the Solarix PLI 5000-48.

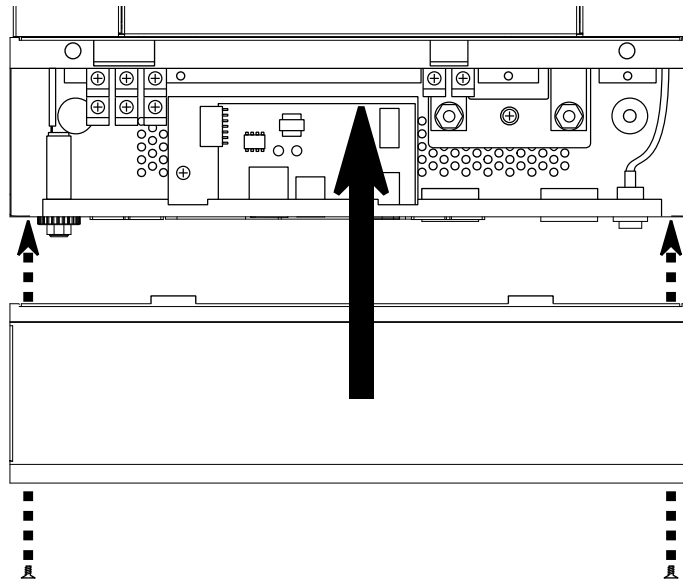

Figure 8: Closing the bottom cover

Solarix PLI 2400-24

1. Before the kit can be installed, unscrew the two screws shown in Fig. 9. Make sure to keep the screws.

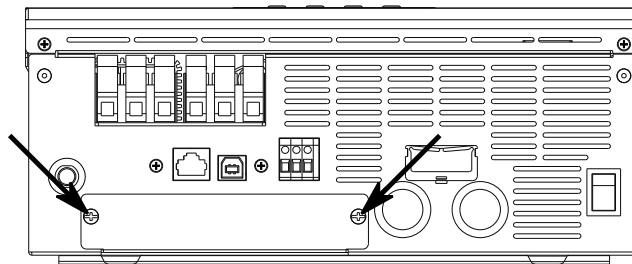

Figure 9: Unscrew parallel board screws

2. Carefully pull out the beige dummy board as shown in Fig. 10. Take care to pull the attached cables out only as far as is absolutely necessary. Do not use excessive force.

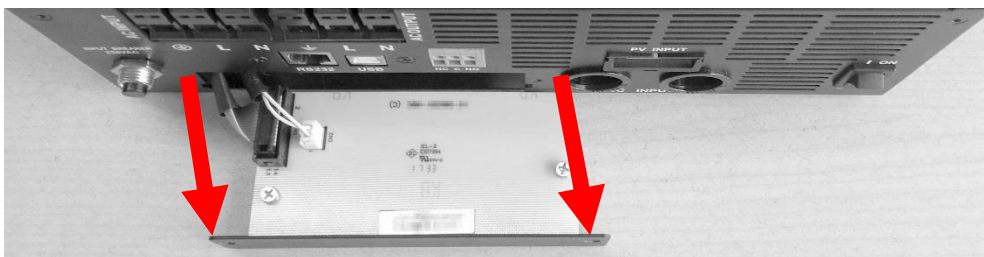

Figure 10: Pull out dummy board

3. Carefully remove the two cable connectors (14-Pin and 2-Pin) on the left of the beige dummy board. The dummy board is no longer required. Now connect the same cable connectors to the same location on the parallel board included in this kit as shown in Fig. 11.



Figure 11: Connected parallel board

4. Slide the parallel board back into the inverter in the same place where the dummy board was previously installed. Screw it in place with the screws removed in Fig. 9.
5. You have now completed the installation of the parallel board into the Solarix PLI 2400-24.

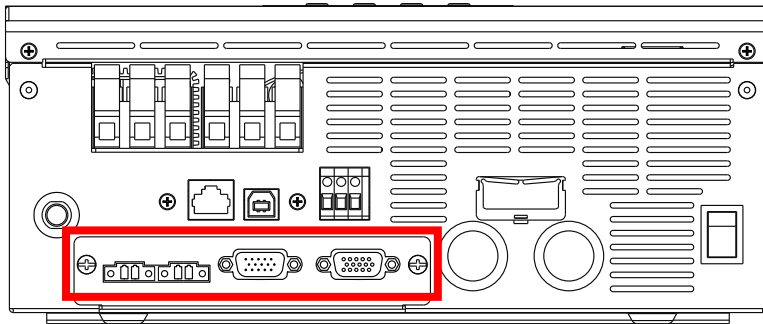

Figure 12: Bottom view of inverter with installed parallel card

Mounting the Inverters

Follow the instructions from the section “**Mounting the Unit**” of the inverter manual. The following points throughout the remainder of this chapter are differences to the installation of a single inverter as described in the inverter manual.

Minimum Distances for Installation of Inverters

Make sure that the minimum distance to walls and other objects is adhered to. Equally, during the installation of multiple inverters make sure the minimum distance between each inverter is at least 20 cm to the side and the inverters are mounted in a horizontal line. Furthermore, no objects may be closer than 50 cm above or below the inverter as shown in Fig. 9 to ensure adequate ventilation.

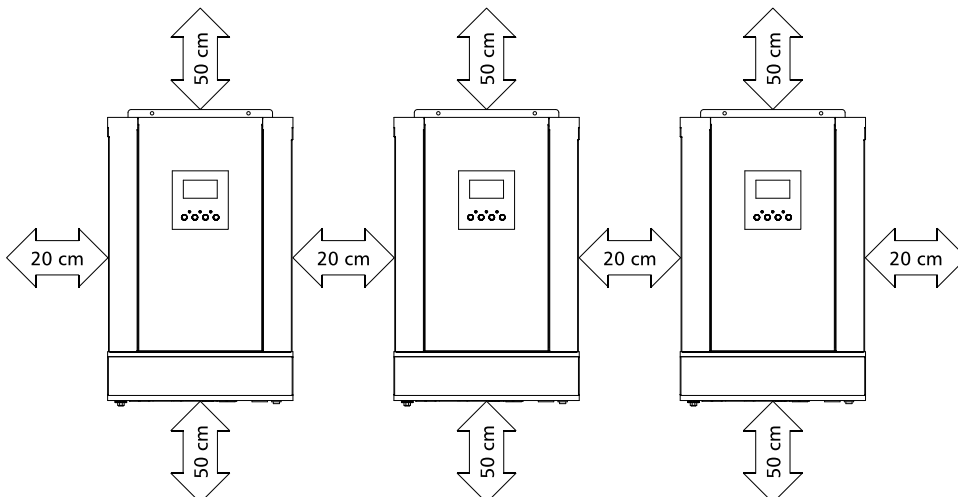

Figure 13: Minimum distance to walls and other objects, including other Solarix PLI inverters

Wiring Considerations

CAUTION: Make sure all connections and the main power button of the inverter remain off by leaving fuses removed or by leaving the circuit breakers open at this point so there is no voltage applied to the inverter. Applying voltage to the inverter or connecting multiple inverters together before installing the parallel communication cable or current sharing cable is likely to cause significant damage to the inverters and other equipment.

Make sure the battery cable length, diameter and material is the same for all inverters interconnected in the 3-phase or parallel system. Otherwise the system may not work reliably.



WARNING: All wiring must be performed by qualified personnel according to local regulations.

It is very important for system safety and efficient operation to use appropriate cable cross-sections and breakers or fuses. Make sure that in any case the selected fuses or breakers are sufficiently sized to protect the cables from significant heat due to excessive currents. Failure to do so could cause uncontrolled heating or fire.

Before connecting the battery, AC input / output and PV module cables, proceed to interconnect the inverters with the parallel communication cables and current sharing cables according to your parallel and / or 3-phase setup as mentioned in the “**Wiring Examples**” section of this manual.

Adhere to the inverter manual for the necessary cable cross-sections to each inverter. For the battery connection from the point where the inverters are tied together (between the battery terminal and where the individual battery cables go to each inverter) the cross-section should be equal or greater to $25 \text{ mm}^2 \times$ number of inverters. So if 9 inverters are used, bus-bars or cables with at least $25 \text{ mm}^2 \times 9 \text{ inverters} = 225 \text{ mm}^2$ should be installed.

AC Wiring

For the AC input and AC output lines the same applies. For the sections where multiple inverters are joined together and from there on forth, the cable cross-section should be equal to or higher than $6 \text{ mm}^2 \times$ number of inverters, so for 9 inverters $6 \text{ mm}^2 \times 9 \text{ inverters} = 54 \text{ mm}^2$.

PV Module Wiring

CAUTION: The PV module cables may never have contact to multiple inverters. Every inverter must have its own array of PV modules with no direct connection to the PV arrays of other inverters or charge controllers, or the inverters may be damaged.

Fuses or Circuit Breakers

Please install a breaker or fuse at the battery connection and AC input of each inverter as explained in the inverter manual. This battery breaker or fuse should be installed as close as possible to the bus bar or the large cross-section cable collecting all the battery cables of the inverters. Each inverter should have a battery breaker or fuse with a rating of 250 Adc to 300 Adc.

For the joint AC input of the inverters (before the AC input is divided up into the individual AC input lines for each inverter) the recommended circuit breaker rating is 40 Aac (for Solarix PLI 5000-48) or 30 Aac (for Solarix PLI 2400-24 x number of inverters on that phase. As an example, for 9x Solarix PLI 5000-48 inverters on a single phase the recommended breaker rating would be 40 A x 9 inverters = 360 A.

In a 3-phase system a 4-pole circuit breaker may be used. Make sure the breaker can withstand the maximum current of at least 40 A per Solarix PLI 5000-48 or 30 A per Solarix PLI 2400-24 on that phase. Also ensure that the AC cables of phases with less inverters are sized adequately as to be protected from the 4-pole breaker. It is strongly recommended to use the same cable cross-section for each phase for this reason, whilst ensuring the cable cross-section can safely withstand 40 A per Solarix PLI 5000-48 or 30 A per Solarix PLI 2400-24 on that phase.

Battery Capacity

The recommended battery capacity is equal to or greater than 200 Ah at per inverter. For a system with 9 inverters: 200 Ah x 9 inverters = 1800 Ah at 48 Vdc for a system with Solarix PLI 5000-48 or 24 Vdc for a Solarix PLI 2400-24 system. It is important that all inverters are **connected to the same battery bank** or they will enter fault mode.

Wiring Examples

The following examples illustrate the wiring of several different combinations of inverters, all equipped with the parallel card. Any connections, such as the PV module connections, that are not shown (to improve readability), are covered by the inverter manual.

Green wires in the communication wiring diagrams represent the current sharing cables and are always connected (if present), to the left two parallel card connectors. The orange wiring shows the parallel communication cables, they are always connected to the right two parallel card connectors. While the 3-phase examples always show phase 1 as having the same or higher number of inverters compared to phase 2 and phase 3, in practice the phase definition can be varied, as long as the phase direction / sequence is adhered to. So while there is an example for 5 inverters on phase 1, 3 inverters on phase 2 and 1 inverter on phase 3, the same example applies to 1 inverter on phase 1, 5 inverters on phase 2 and 3 inverters on phase 3. In such a case make sure to program each inverter accordingly as mentioned in the chapter "**Configuration**" (specifically the phase definition of program 28) and substitute the phase definitions in the example diagrams accordingly.

The circuit breakers  shown in the examples are required (one circuit breaker each in the positive and negative battery lines is recommended and shown, but not required, one battery circuit breaker is technically sufficient). Make sure to follow local regulations.

CAUTION: Never connect current sharing cables between the inverters that are on different phases. Doing so is likely to damage the inverters.

The wiring of the parallel card must take place before the inverter breakers to the battery and AC source are closed / turned on and before the inverters are powered on to prevent damage.

The inverter supports single phase or 3-phase modes only. Split-phase or other 2-phase configurations are likely to damage the inverters. In 2-phase systems each phase must be treated separately (no communication or current sharing cables between inverters on the different phases) and cannot be synchronised to the other phase. On each phase one or multiple inverters can be used, as in any single phase parallel system.

Parallel Operation of Two Inverters on Single Phase

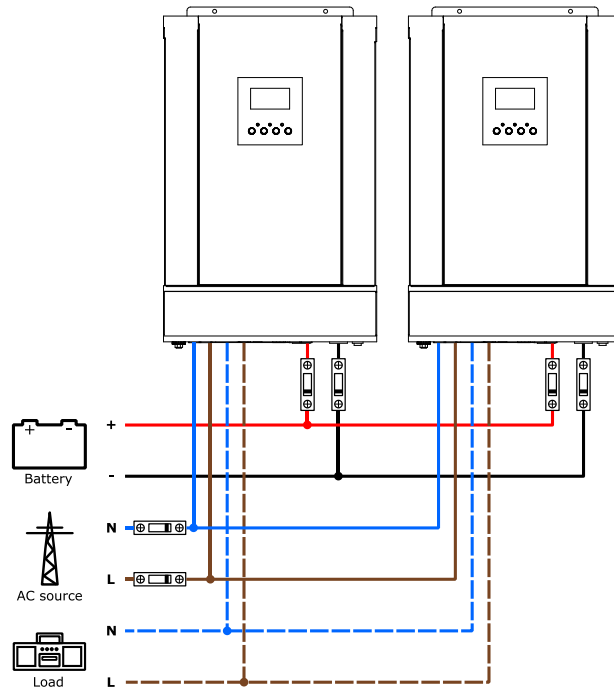

Figure 14: Wiring of two parallel inverters on single phase



Figure 15: Communication wiring of two parallel inverters on single phase

Parallel Operation of Three Inverters on a Single Phase

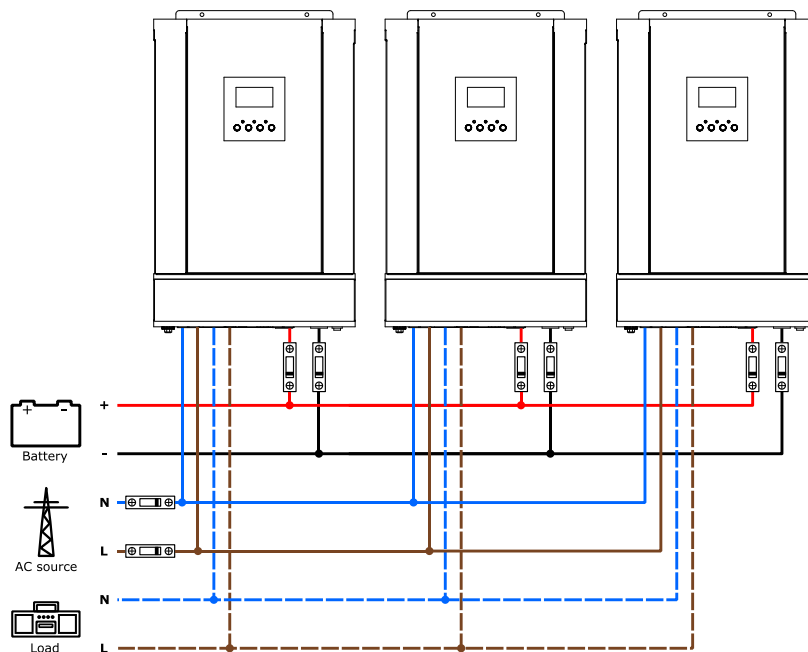

Figure 16: Wiring of three parallel inverters on single phase

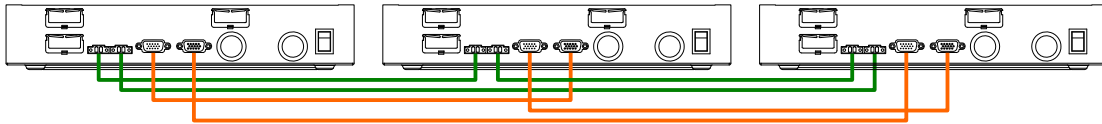

Figure 17: Communication wiring of three parallel inverters on single phase

Parallel Operation of Four Inverters on a Single Phase

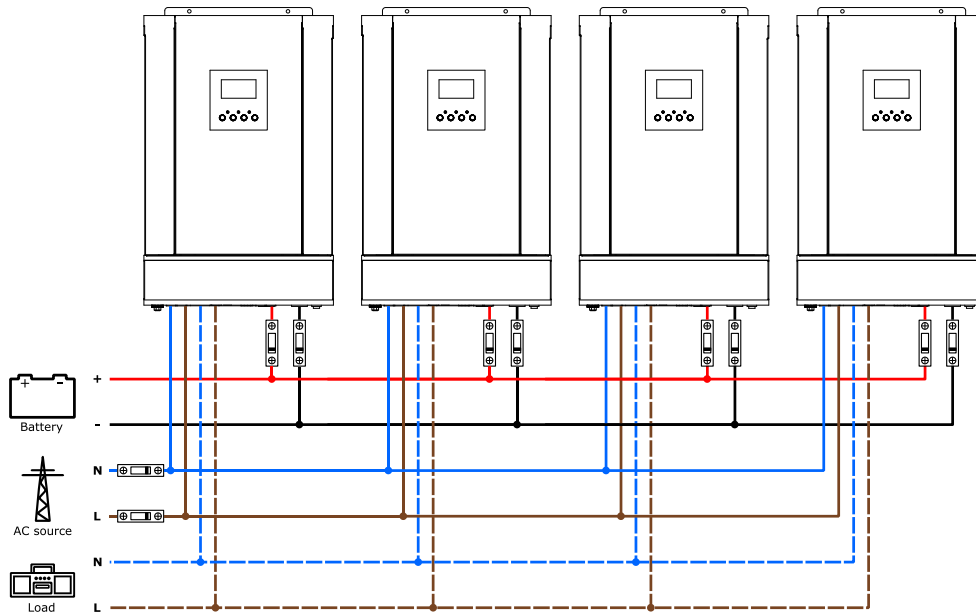

Figure 18: Wiring of four parallel inverters on single phase

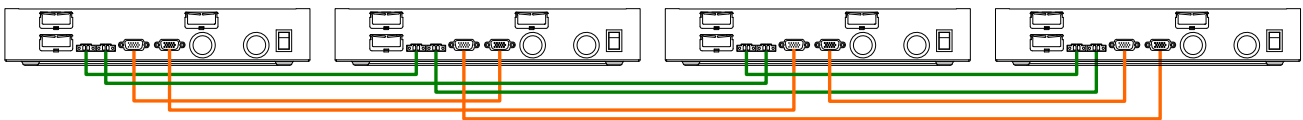

Figure 19: Communication wiring of four parallel inverters on single phase

Parallel Operation of Five Inverters on a Single Phase

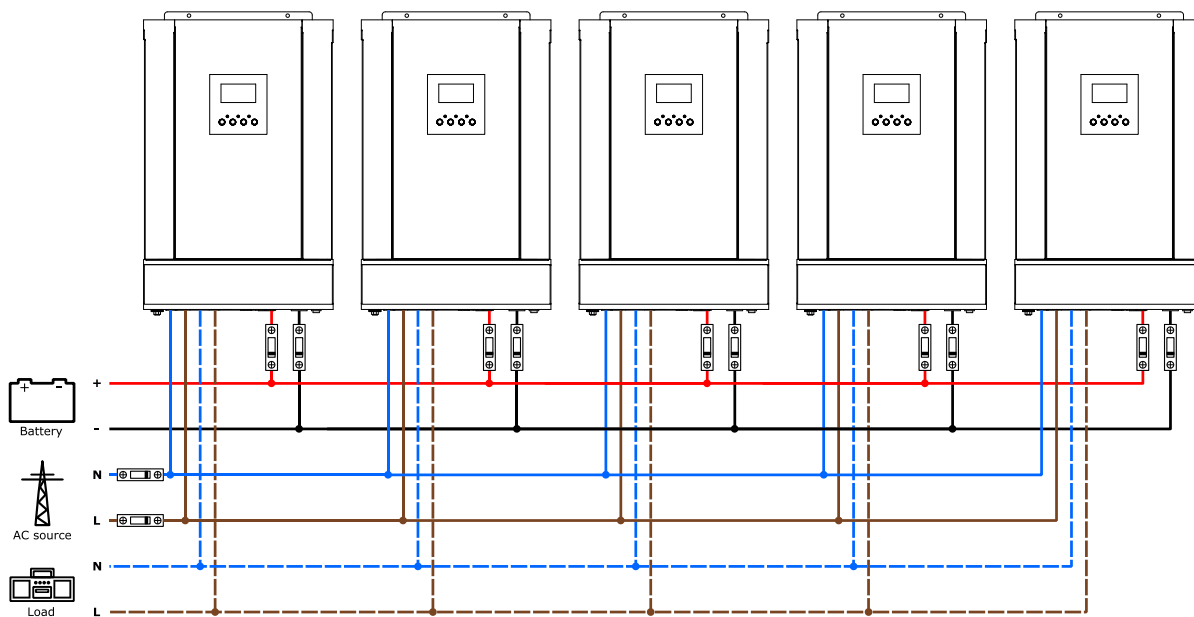

Figure 20: Wiring of five parallel inverters on single phase

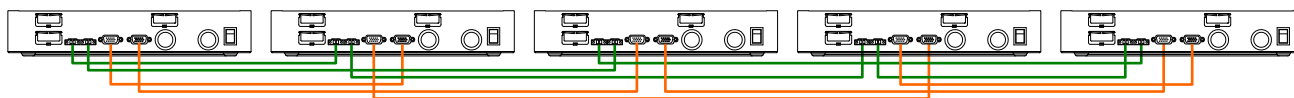

Figure 21: Communication wiring of five parallel inverters on single phase

Parallel Operation of Six Inverters on a Single Phase

As the AC and battery wiring is apparent in Fig. 20, this concept can equally be applied to six inverters on a single phase.

To improve readability, only the relevant connections to the parallel card are shown below.

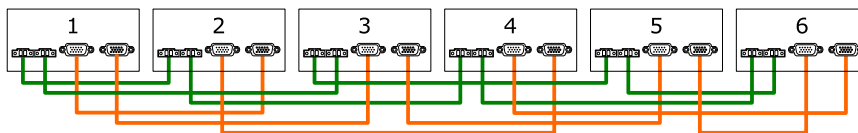

Figure 22: Communication wiring of six parallel inverters on single phase

Parallel Operation of Seven Inverters on a Single Phase

As the AC and battery wiring is apparent in Fig. 20, this concept can equally be applied to seven inverters on a single phase.

To improve readability, only the relevant connections to the parallel card are shown below.

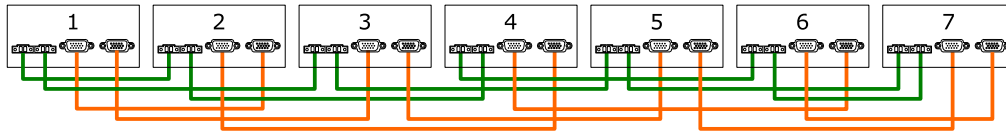

Figure 23: Communication wiring of seven parallel inverters on single phase

Parallel Operation of Eight Inverters on a Single Phase

As the AC and battery wiring is apparent in Fig. 20, this concept can equally be applied to eight inverters on a single phase.

To improve readability, only the relevant connections to the parallel card are shown below.

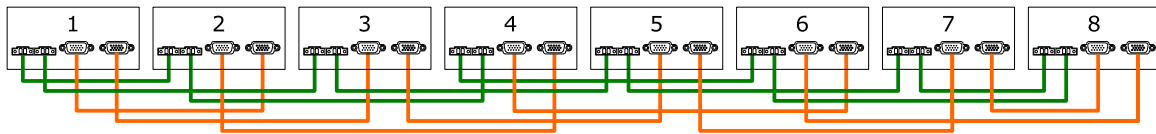

Figure 24: Communication wiring of eight parallel inverters on single phase

Parallel Operation of Nine Inverters on a Single Phase

As the AC and battery wiring is apparent in Fig. 20, this concept can equally be applied to nine inverters on a single phase.

To improve readability, only the relevant connections to the parallel card are shown below.

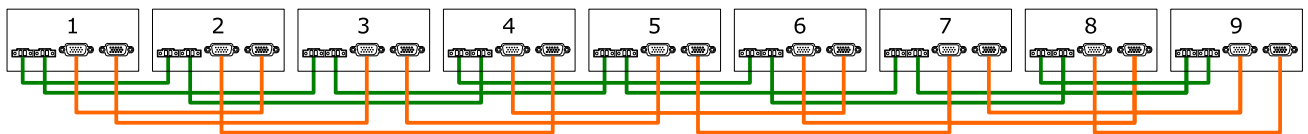

Figure 25: Communication wiring of nine parallel inverters on single phase

3-Phase Operation of Three Inverters (1 + 1 + 1)

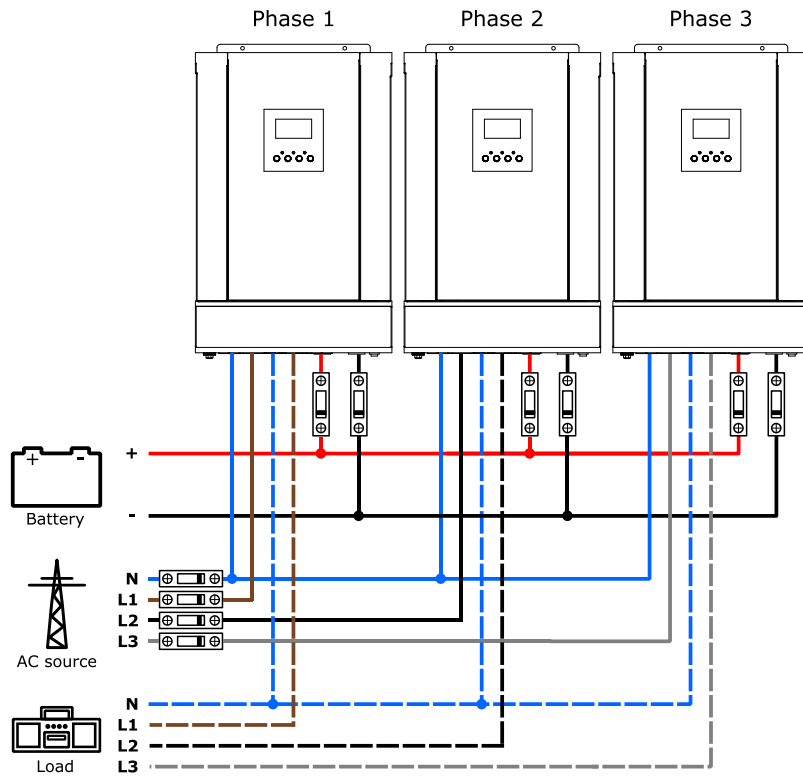

Figure 26: Wiring of three inverters in a 3-phase system

To improve readability, only the relevant connections to the parallel card are shown below.

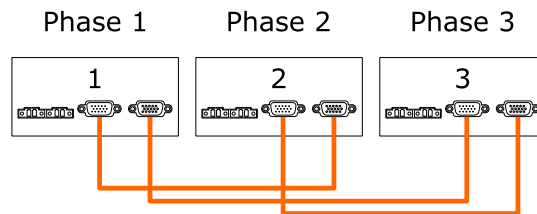

Figure 27: Communication wiring of three inverters in a 3-phase system

3-Phase Operation of Four Inverters (2 + 1 + 1)

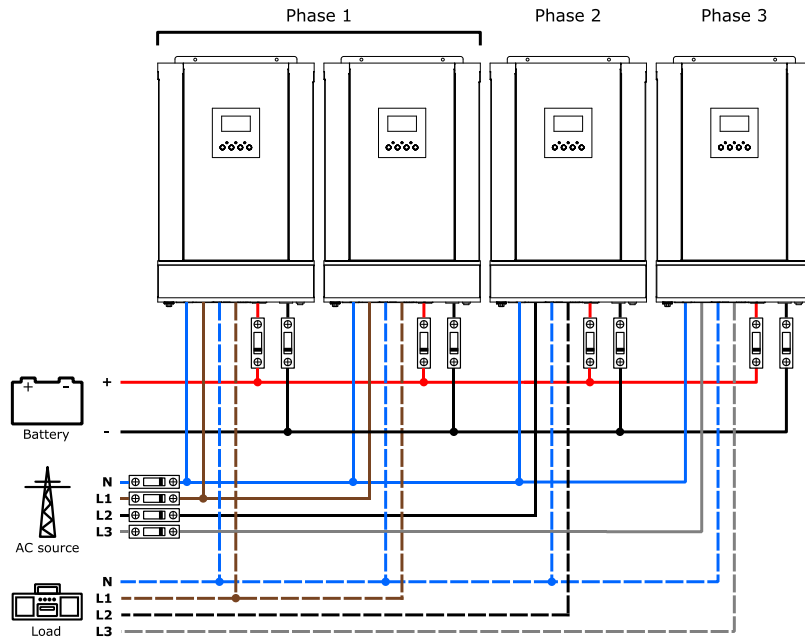

Figure 28: Wiring of four inverters in a 3-phase system (2 + 1 + 1)

To improve readability, only the relevant connections to the parallel card are shown below.

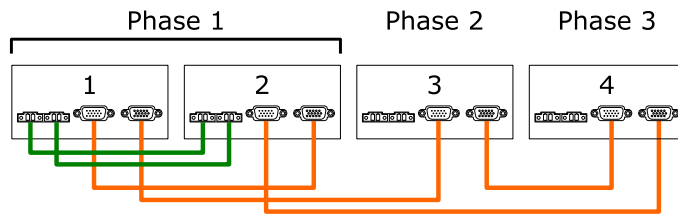

Figure 29: Communication wiring of four inverters in a 3-phase system (2 + 1 + 1)

3-Phase Operation of Five Inverters (3 + 1 + 1)

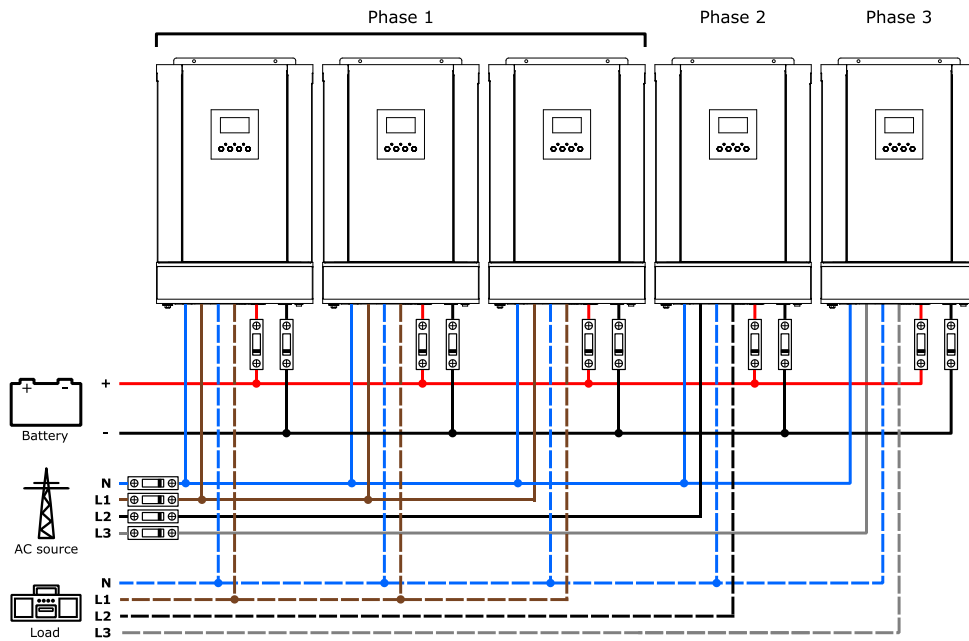

Figure 30: Wiring of five inverters in a 3-phase system (3 + 1 + 1)

To improve readability, only the relevant connections to the parallel card are shown below.

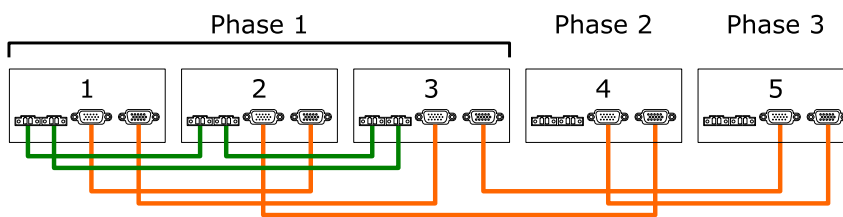

Figure 31: Communication wiring of five inverters in a 3-phase system (3 + 1 + 1)

3-Phase Operation of Five Inverters (2 + 2 + 1)

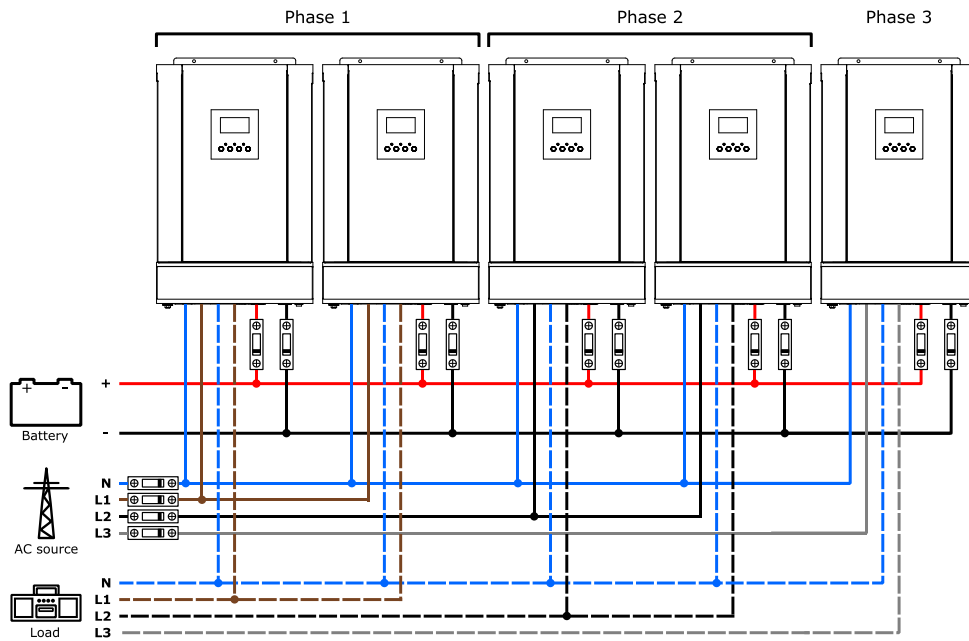

Figure 32: Wiring of five inverters in a 3-phase system (2 + 2 + 1)

To improve readability, only the relevant connections to the parallel card are shown below.

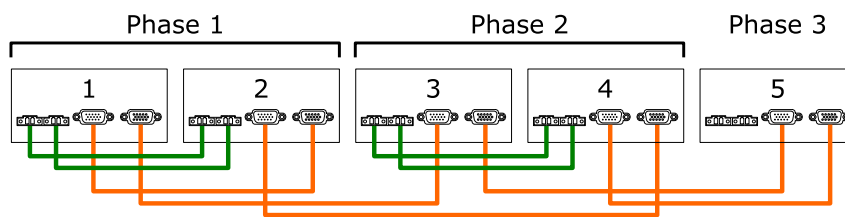

Figure 33: Communication wiring of five inverters in a 3-phase system (2 + 2 + 1)

3-Phase Operation of Six Inverters (3 + 2 + 1)

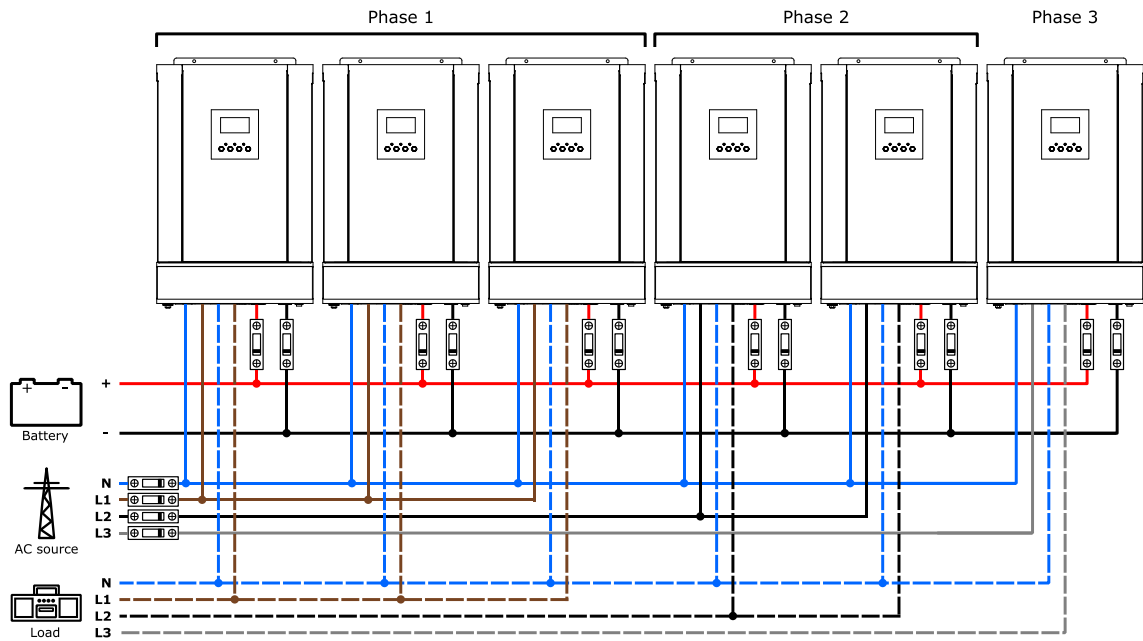

Figure 34: Wiring of six inverters in a 3-phase system (3 + 2 + 1)

To improve readability, only the relevant connections to the parallel card are shown below.

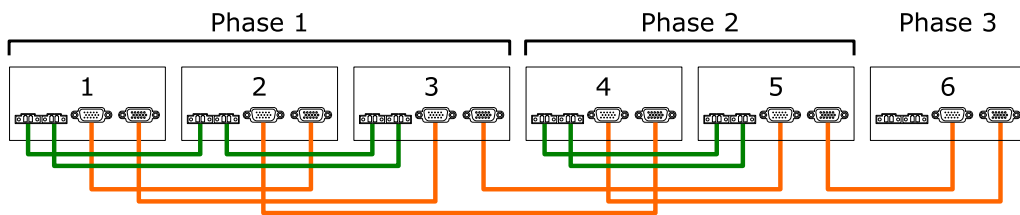

Figure 35: Communication wiring of six inverters in a 3-phase system (3 + 2 + 1)

3-Phase Operation of Six Inverters (4 + 1 + 1)

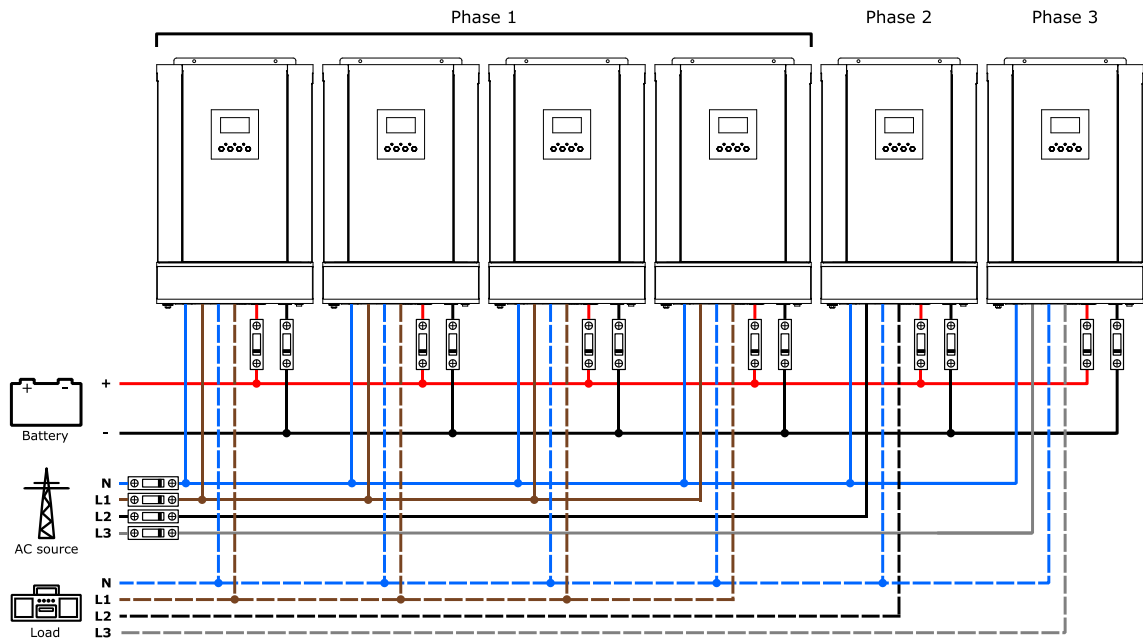

Figure 36: Wiring of six inverters in a 3-phase system (4 + 1 + 1)

To improve readability, only the relevant connections to the parallel card are shown below.

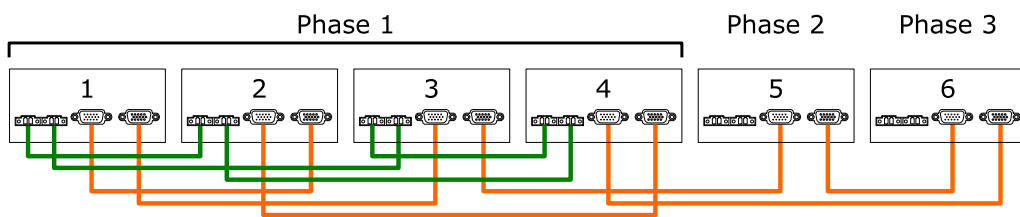

Figure 37: Communication wiring of six inverters in a 3-phase system (4 + 1 + 1)

3-Phase Operation of Six Inverters (2 + 2 + 2)

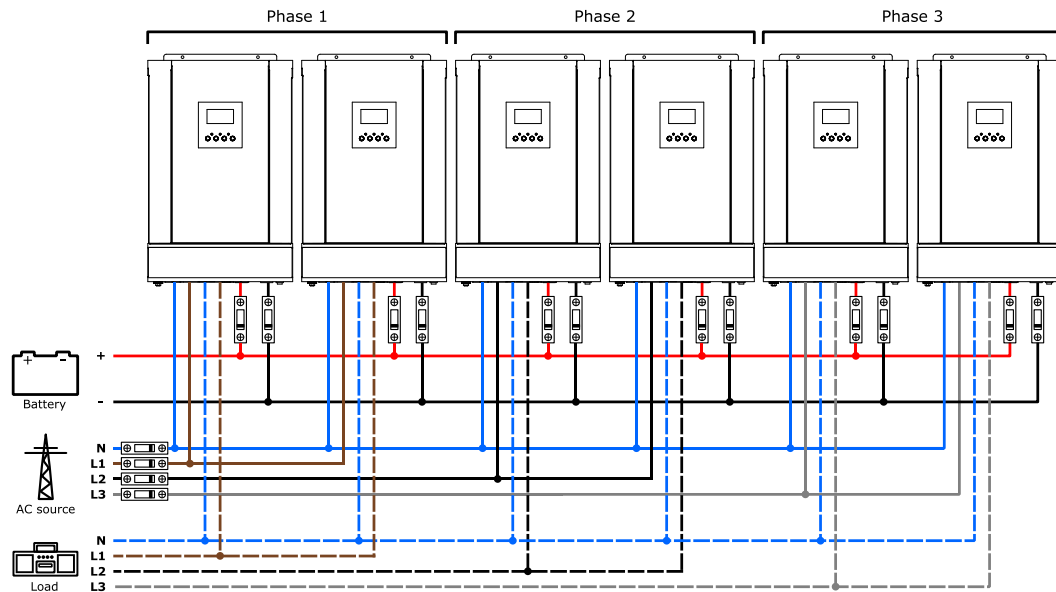

Figure 38: Wiring of six inverters in a 3-phase system (2 + 2 + 2)

To improve readability, only the relevant connections to the parallel card are shown below.

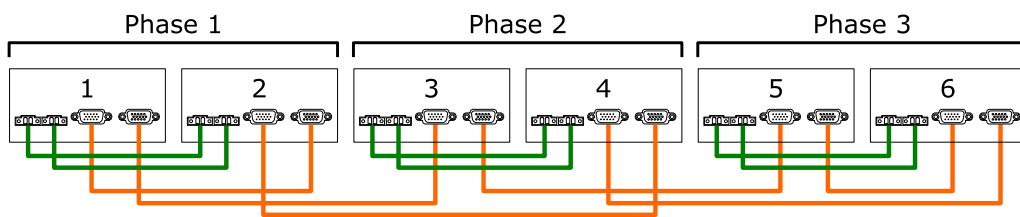

Figure 39: Communication wiring of six inverters in a 3-phase system (2 + 2 + 2)

3-Phase Operation of Seven Inverters (3 + 3 + 1)

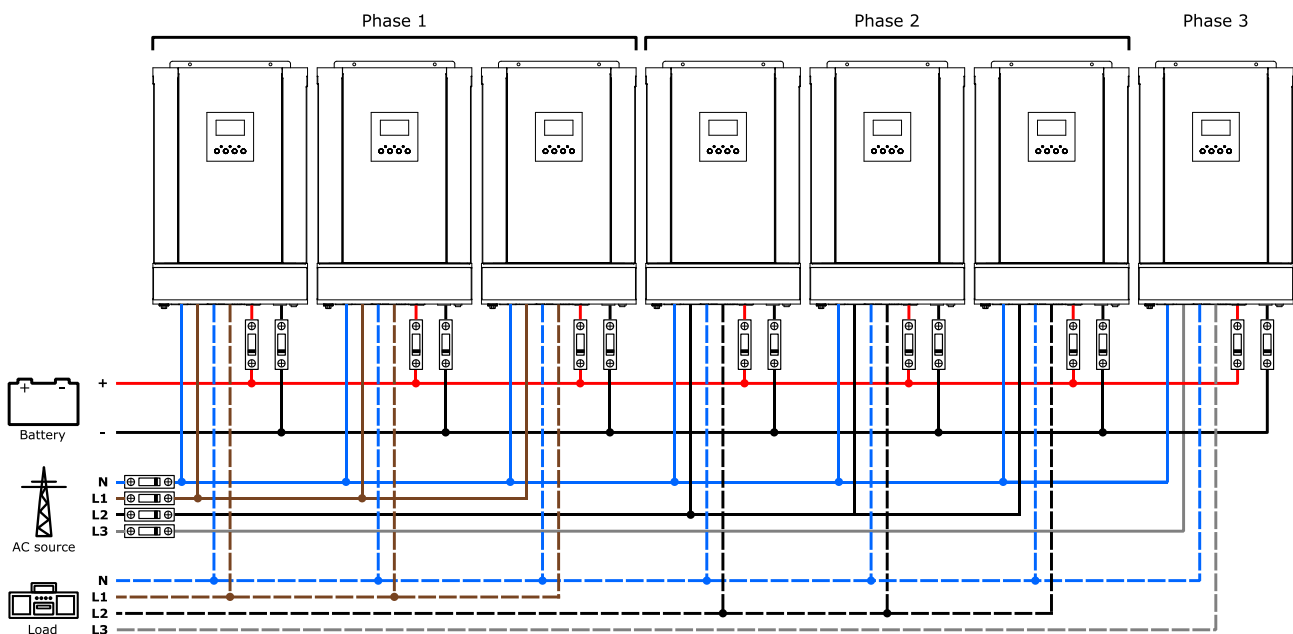

Figure 40: Wiring of seven inverters in a 3-phase system (3 + 3 + 1)

To improve readability, only the relevant connections to the parallel card are shown below.

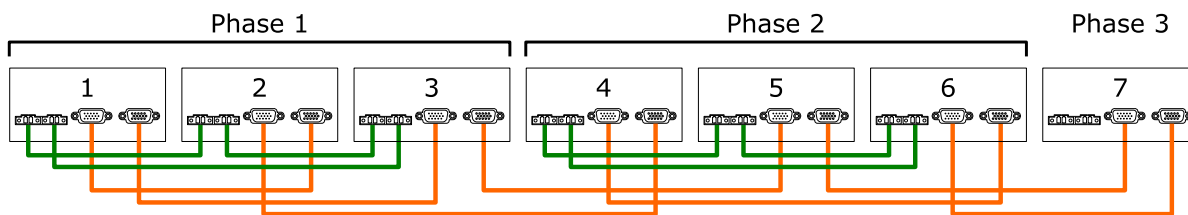

Figure 41: Communication wiring of seven inverters in a 3-phase system (3 + 3 + 1)

3-Phase Operation of Seven Inverters (4 + 2 + 1)

Refer to Fig. 34 for AC and battery wiring, add one inverter in parallel to phase 1.

To improve readability, only the relevant connections to the parallel card are shown below.

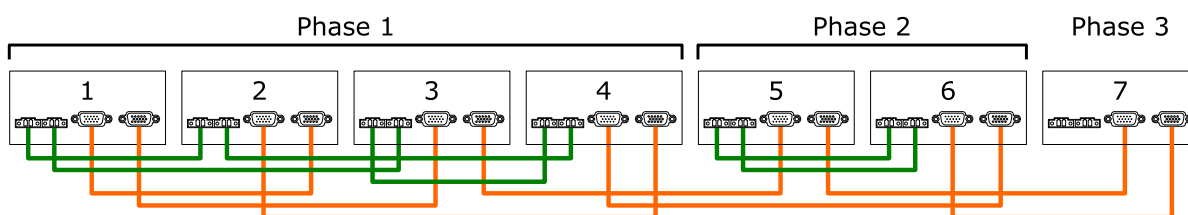

Figure 42: Communication wiring of seven inverters in a 3-phase system (4 + 2 + 1)

3-Phase Operation of Seven Inverters (3 + 2 + 2)

Refer to Fig. 34 for AC and battery wiring, add one inverter in parallel to phase 3.

To improve readability, only the relevant connections to the parallel card are shown below.

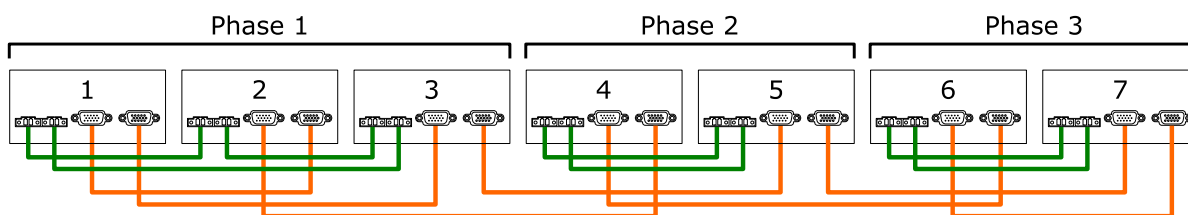

Figure 43: Communication wiring of seven inverters in a 3-phase system (3 + 2 + 2)

3-Phase Operation of Seven Inverters (5 + 1 + 1)

Refer to Fig. 36 for AC and battery wiring, add one inverter in parallel to phase 1.

To improve readability, only the relevant connections to the parallel card are shown below.

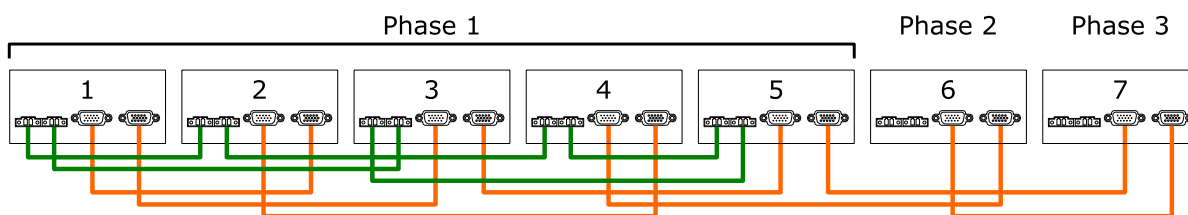

Figure 44: Communication wiring of seven inverters in a 3-phase system (5 + 1 + 1)

3-Phase Operation of Eight Inverters (4 + 2 + 2)

Refer to Fig. 38 for AC and battery wiring, add two inverters in parallel to phase 1.
To improve readability, only the relevant connections to the parallel card are shown below.

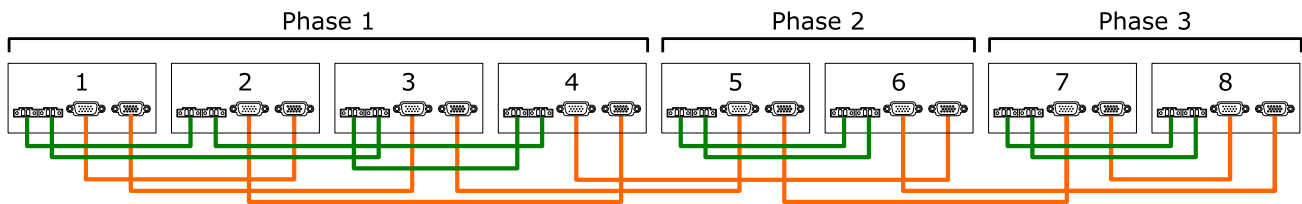

Figure 45: Communication wiring of eight inverters in a 3-phase system (4 + 2 + 2)

3-Phase Operation of Eight Inverters (5 + 2 + 1)

Refer to Fig. 34 for AC and battery wiring, add two inverters in parallel to phase 1.
To improve readability, only the relevant connections to the parallel card are shown below.

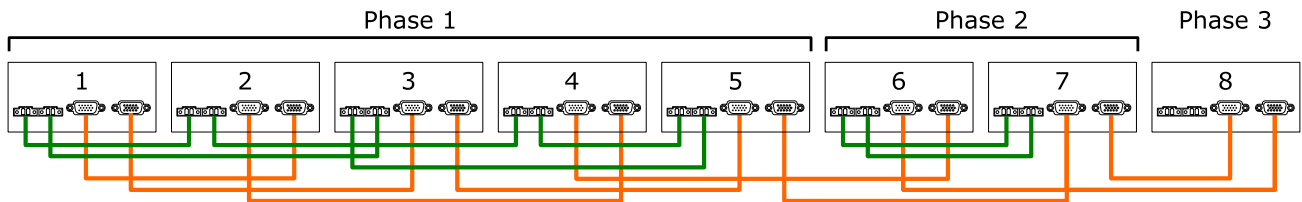

Figure 46: Communication wiring of eight inverters in a 3-phase system (5 + 2 + 1)

3-Phase Operation of Eight Inverters (3 + 3 + 2)

Refer to Fig. 40 for AC and battery wiring, add one inverter in parallel to phase 3.
To improve readability, only the relevant connections to the parallel card are shown below.

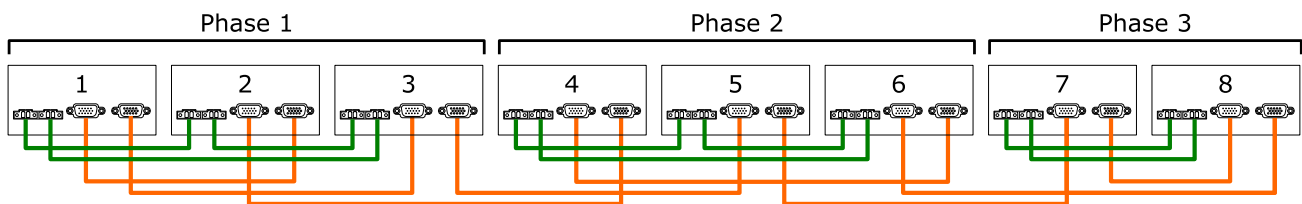

Figure 47: Communication wiring of eight inverters in a 3-phase system (3 + 3 + 2)

3-Phase Operation of Eight Inverters (4 + 3 + 1)

Refer to Fig. 40 for AC and battery wiring, add one inverter in parallel to phase 1.
To improve readability, only the relevant connections to the parallel card are shown below.

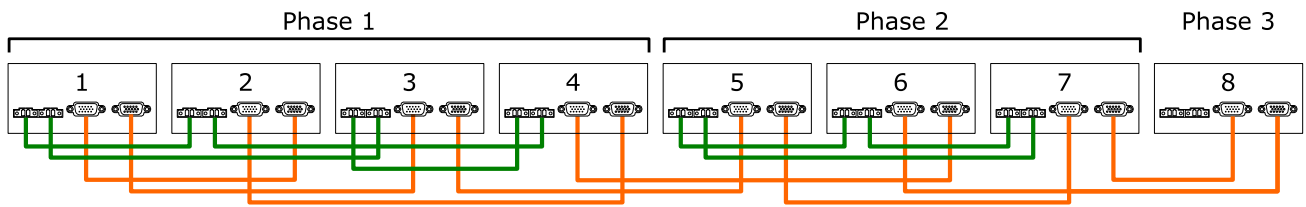

Figure 48: Communication wiring of eight inverters in a 3-phase system (4 + 3 + 1)

3-Phase Operation of Nine Inverters (3 + 3 + 3)

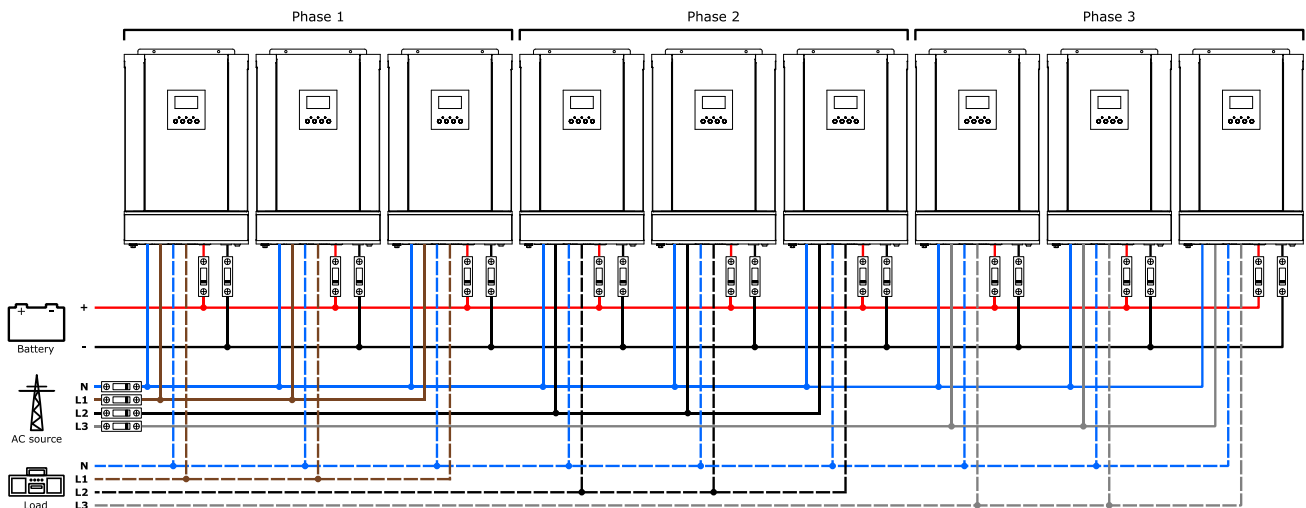

Figure 49: Wiring of nine inverters in a 3-phase system (3 + 3 + 3)

To improve readability, only the relevant connections to the parallel card are shown below.

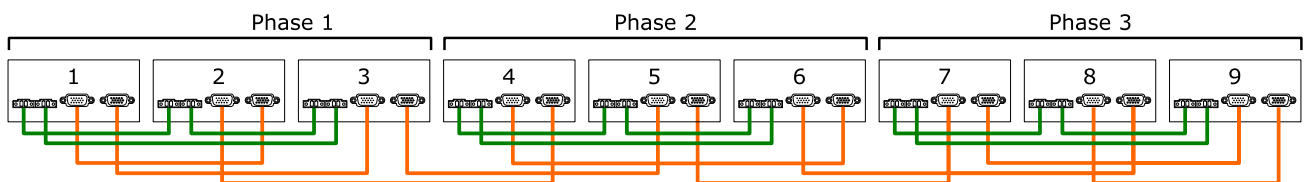

Figure 50: Communication wiring of nine inverters in a 3-phase system (3 + 3 + 3)

3-Phase Operation of Nine Inverters (4 + 3 + 2)

Refer to Fig. 38 for AC and battery wiring, add two inverters in parallel to phase 1 and one inverter in parallel to phase 2.

To improve readability, only the relevant connections to the parallel card are shown below.

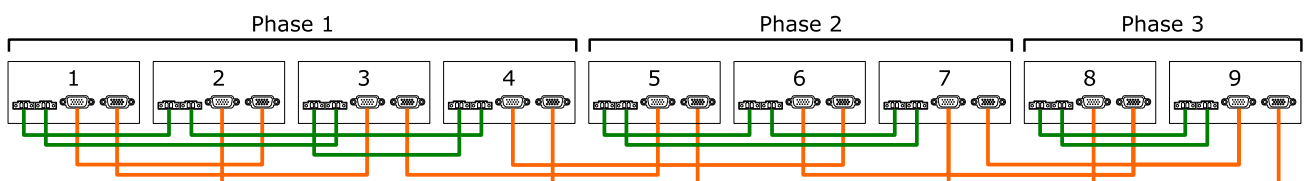

Figure 51: Communication wiring of nine inverters in a 3-phase system (4 + 3 + 2)

3-Phase Operation of Nine Inverters (4 + 4 + 1)

Refer to Fig. 40 for AC and battery wiring, add one inverter in parallel to phase 1 and one inverter in parallel to phase 2.

To improve readability, only the relevant connections to the parallel card are shown below.

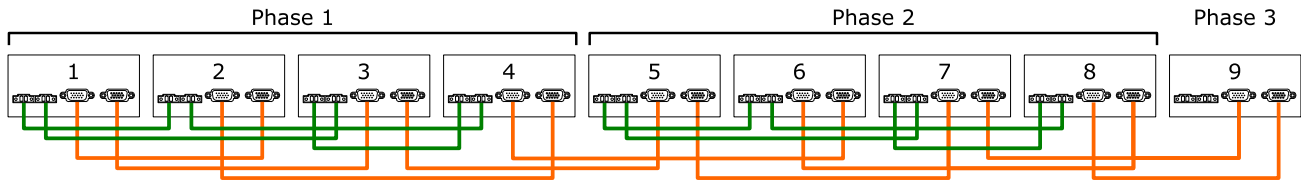

Figure 52: Communication wiring of nine inverters in a 3-phase system (4 + 4 + 1)

3-Phase Operation of Nine Inverters (5 + 2 + 2)

Refer to Fig. 38 for AC and battery wiring, add three inverters in parallel to phase 1.

To improve readability, only the relevant connections to the parallel card are shown below.

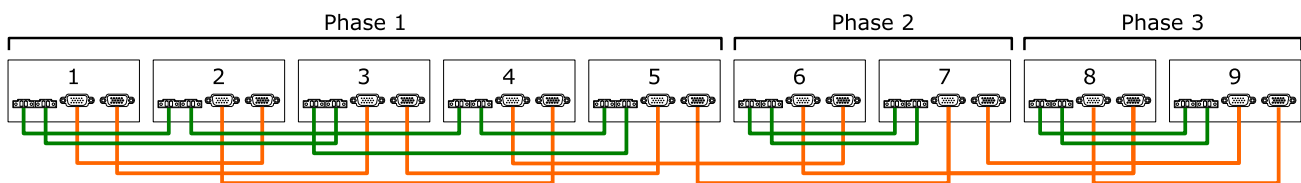

Figure 53: Communication wiring of nine inverters in a 3-phase system (5 + 2 + 2)

3-Phase Operation of Nine Inverters (5 + 3 + 1)

Refer to Fig. 40 for AC and battery wiring, add two inverters in parallel to phase 1.

To improve readability, only the relevant connections to the parallel card are shown below.

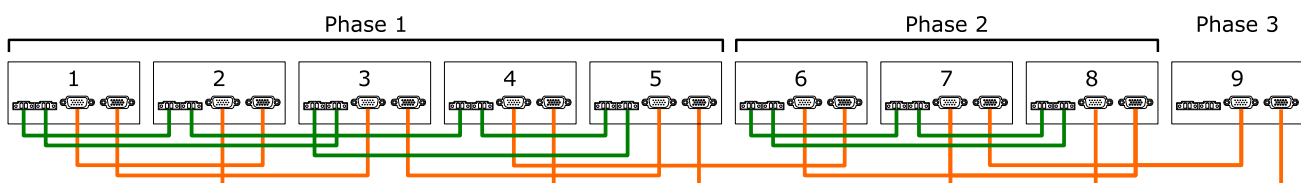

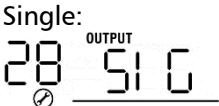



Figure 54: Communication wiring of nine inverters in a 3-phase system (5 + 3 + 1)



Configuration

This chapter illustrates the configuration options. The actual commissioning of the system and setting of the configurations is explained in the following chapter “Commissioning”.

CAUTION: All AC and DC connections must remain off at this point. No battery, PV, AC loads or AC sources may be connected to any of the inverters. All inverters’ power buttons must be in the “OFF” position. Refer to the chapter “Commissioning” for the further procedure.

Setting Programs:

Program	Description	Selectable option	
28	<p>AC output mode</p> <p>This setting is only saved when the inverter is in standby mode and is then turned on again (the power button must be in the “OFF” position on the inverter).</p>	Single: 	<p>When the units are used in parallel and in a single phase system, please select “PAL” in program 28. Up to 9 inverters may be connected in parallel in one phase.</p>
		Parallel: 	<p>It is required to have at least 3 inverters or a maximum of 9 inverters for the 3-phase mode. At least one inverter is needed in each phase and up to seven inverters maximum in one phase. Please refer to the chapters “Introduction” and “Wiring Examples” for detailed information.</p>
		L1 phase: 	<p>Please select “3P1” in program 28 in the inverters connected to L1 phase, “3P2” in program 28 for the inverters connected to L2 phase and “3P3” in program 28 for the inverters connected to L3 phase.</p>
		L2 phase: 	
		L3 phase: 	<p>Be sure to connect the current sharing cable to all units which are on the same phase, as shown in “Wiring Examples”. Do not connect current sharing cables between units on different phases.</p> <p>Enabling any setting in program 28 apart from “Single” means the power saving function will be automatically disabled.</p>

<p>30</p>	<p>PV condition rule</p> <p>This setting only applies if "Solar first" is selected in program 1 (see inverter manual) as the output source priority.</p>	<p>One inverter (default):</p> 	<p>When this "One inverter" setting is selected, as long as at least one of the inverters has been connected to PV modules and the PV input is operating normally, the parallel or 3-phase system will work according to the rules of the "Solar first" setting.</p> <p>Example: two units are connected in parallel and set to "Solar first" as the output source priority. If one of the two units is connected to PV modules and the PV input is operating normally (there is some PV power available), the parallel system will provide power to loads from solar and / or battery power. If both of the inverters' PV input power levels are not sufficient, the system will provide power to loads from the AC source.</p>
		<p>All of the inverters:</p> 	<p>When this "All of the inverters" setting is selected, parallel or 3-phase systems will continue working according to the rules of the "Solar first" setting only when all of inverters are connected to PV modules and all the PV inputs are operating normally.</p> <p>Example: two units are connected in parallel and set to "Solar first" as the output source priority. When selecting "All of the inverters" in program 30, all inverters must be connected to PV modules and the PV input of all inverters must be normal (there is some PV power available) to allow the system to provide power to loads from solar and battery power. Otherwise, the system will provide power to loads from the AC source.</p>

Commissioning

Once the wiring of all inverters in the system is correct and completed, ensure that all breakers are open or fuses removed (Battery, PV and AC input), and that no loads are connected to the AC outputs of the inverters (or, if installed, the AC output breaker is open).

Note: The transfer time between AC input / grid mode and inverter / off-grid mode may increase from 10 ms (in UPS mode) up to a maximum of 50 ms by interconnecting multiple inverters. Ensure that the connected AC loads are capable of withstanding AC power losses up to 50 ms if using an AC source.

CAUTION: All connections, particularly AC connections must remain off. No AC loads or AC sources may be connected to any of the inverters until after the following commissioning procedure.

Parallel Inverters on a Single Phase

Follow the following steps after wiring the units as per the chapters “Wiring Considerations” and “Wiring Examples” in the case of a single phase system.

1. Ensure the following requirements are met:
 - a. Make sure all inverters in the system are correctly wired, that all inverters’ neutral wires on the AC input side are connected together, and that all inverters’ neutral wires on the AC output side are connected together
 - b. Ensure the AC input circuit breakers are open / disconnected and that the AC loads are disconnected (or, if installed, the AC output breaker is open)
 - c. Make sure the power button of each inverter is in the “OFF” position
2. Turn on one inverter by closing / switching on the battery circuit breaker or inserting the battery fuse. Now switch the power button to the “ON” position of that same inverter. Enter the configuration / setting mode the inverter by pressing the “MENU” button for 3 seconds. Go to program 28 in the settings menu.
3. Turn off the same inverter by switching the power button to the “OFF” position. The inverter’s LCD will remain on for about 30 seconds. During this time set program 28 to “Parallel” as explained in the chapter “Configuration” of this manual. Now exit the setting mode. After a few seconds the inverter will turn off completely.

Note: It is necessary to turn the inverter off in order for the setting in program 28 to be modifiable.
4. Repeat steps 1 to 3 for each other inverter until all inverters have been configured. When finished turn on each inverter (switch the power button to the “ON” position). Now the inverters displays will show the following:

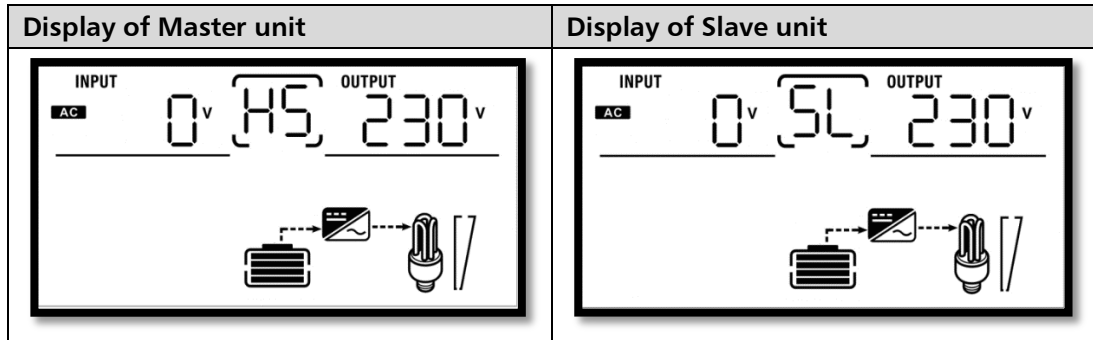

Note: One unit will randomly be defined as the Master unit, the others will be defined as Slave units.

- Switch on / close the circuit breaker(s) of the AC input source. If using multiple circuit breakers between the AC source and the inverters try to switch them all on as quickly as possible. If they are not switched on at the same time, the inverter(s) not yet electrically connected to the AC source may show Fault 82 as described in the chapter “**Fault Reference Codes**” as soon as the first inverter AC source is connected. The inverters showing the fault will re-start automatically. Once they have successfully detected the AC input source they will operate normally and the fault is cleared, showing the following on the LCD:

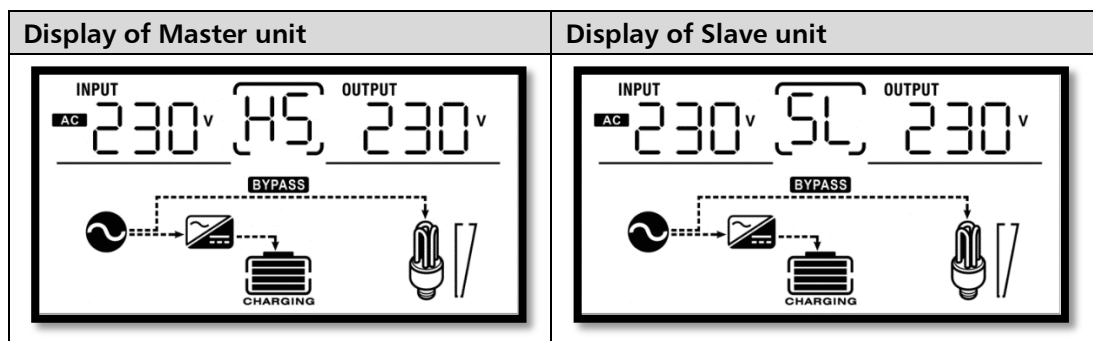

- If there are no more faults / alarms, the parallel system is successfully installed and commissioned.
- Turn on the AC loads by closing / switching on the corresponding breakers. If no breaker is used, turn off all inverters, insert the AC output cables and then start the inverters again.
- Turn on the PV array if available by closing the corresponding breaker or inserting the fuse. If no breaker is used, turn off all inverters, insert the PV array cables and then start the inverters again.

Inverters in a 3-phase Configuration

Follow the following steps after wiring the units as per the chapters “**Wiring Considerations**” and “**Wiring Examples**” in the case of a 3-phase system.

- Ensure the following requirements are met:
 - Make sure all inverters in the system are correctly wired, that all inverters’ neutral wires on the AC input side are connected together, and that all inverters’ neutral wires on the AC output side are connected together

- b. Ensure the AC input circuit breakers are open / disconnected and that the AC loads are disconnected (or, if installed, the AC output breaker is open)
 - c. Make sure the power button of each inverter is in the "OFF" position
 2. Turn on one inverter on phase 1 by closing / switching on the battery circuit breaker or inserting the battery fuse. Now switch the power button to the "ON" position of that same inverter. Enter the configuration / setting mode the inverter by pressing the "MENU" button for 3 seconds. Go to program 28 in the settings menu.
 3. Turn off the same inverter by switching the power button to the "OFF" position. The inverter's LCD will remain on for about 30 seconds. During this time set program 28 to "L1 phase" as explained in the chapter "Configuration" of this manual. Now exit the setting mode, after a few seconds the inverter will turn off completely.

Note: It is necessary to turn the inverter off in order for the setting in program 28 to be modifiable.
 4.
 - a. Repeat steps 1 to 3 for each other inverter on phase 1 (if there are any more inverters on phase 1).
 - b. When finished repeat steps 1 to 3 for each inverter on phase 2, setting program 28 to "L2 phase".
 - c. When finished repeat steps 1 to 3 for each inverter on phase 3, setting program 28 to "L3 phase".
 - d. When finished turn on each inverter (switch the power button to the "ON" position).
Now the inverters displays will show the following:

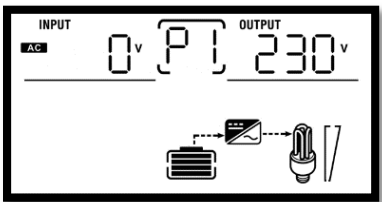
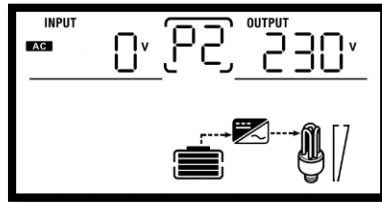
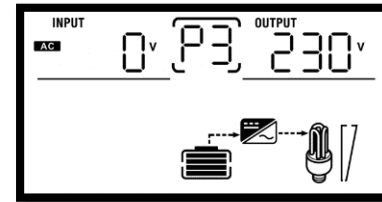
Display on L1 / phase 1 unit	Display on L2 / phase 2 unit	Display on L3 / phase 3 unit
 <p>The LCD display for the L1 phase 1 unit shows 'INPUT' as 0v and 'OUTPUT' as 230v. The phase indicator 'P1' is displayed between the input and output values. Below the display is a schematic diagram showing a battery pack connected to an inverter, which is connected to a light bulb.</p>	 <p>The LCD display for the L2 phase 2 unit shows 'INPUT' as 0v and 'OUTPUT' as 230v. The phase indicator 'P2' is displayed between the input and output values. Below the display is a schematic diagram showing a battery pack connected to an inverter, which is connected to a light bulb.</p>	 <p>The LCD display for the L3 phase 3 unit shows 'INPUT' as 0v and 'OUTPUT' as 230v. The phase indicator 'P3' is displayed between the input and output values. Below the display is a schematic diagram showing a battery pack connected to an inverter, which is connected to a light bulb.</p>

5. Switch on / close the circuit breaker(s) of the AC input source. If using multiple circuit breakers between the AC source and the inverters try to switch them all on as quickly as possible. If they are not switched on at the same time, the inverter(s) not yet electrically connected to the AC source may show Fault 82 as described in the chapter "Fault Reference Codes" as soon as the first inverter AC source is connected. The inverters showing the fault will re-start automatically. Once they have successfully detected the AC input source they will operate normally and the fault is cleared.

Once all 3 phases are activated and all inverters detect the phases correctly, they will operate normally and show the information below on their displays. If this is not the case, then the  symbol will flash and AC input / line mode will not function.

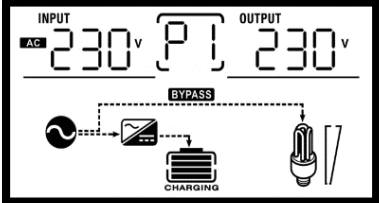
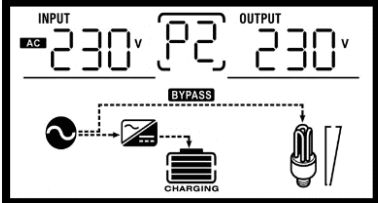
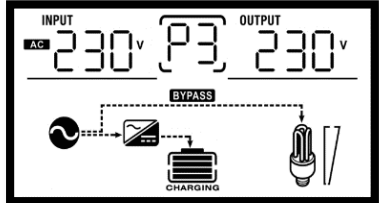









Display on L1 / phase 1 unit	Display on L2 / phase 2 unit	Display on L3 / phase 3 unit
 <p>The display shows 'INPUT AC 230v', 'OUTPUT 230v', and 'P1'. Below the display, a diagram shows a bypass switch in the 'BYPASS' position, with a battery icon labeled 'CHARGING' and a light bulb icon.</p>	 <p>The display shows 'INPUT AC 230v', 'OUTPUT 230v', and 'P2'. Below the display, a diagram shows a bypass switch in the 'BYPASS' position, with a battery icon labeled 'CHARGING' and a light bulb icon.</p>	 <p>The display shows 'INPUT AC 230v', 'OUTPUT 230v', and 'P3'. Below the display, a diagram shows a bypass switch in the 'BYPASS' position, with a battery icon labeled 'CHARGING' and a light bulb icon.</p>

6. If there are no more faults / alarms, the 3-phase system is successfully installed and commissioned.

7. Turn on the AC loads by closing / switching on the corresponding breakers.
 If no breaker is used, turn off all inverters, insert the AC output cables and then start the inverters again. In this case the inverters could be overloaded if they are not all running before the loads are activated.

8. Turn on the PV array if available by closing the corresponding breaker or inserting the fuse. If no breaker is used, turn off all inverters, insert the PV array cables and then start the inverters again.

Fault Reference Codes

Fault Code	Fault Event	Display symbol shown
60	Power feedback protection	
71	Firmware version inconsistent	
72	Current sharing fault	
80	CAN fault	
81	Host loss	
82	Synchronisation loss	
83	Battery voltage detected inconsistent	
84	AC input voltage and frequency detected inconsistent	
85	AC output current unbalanced	
86	AC output mode setting inconsistent	

Troubleshooting

Problem		What to do
Fault Code	Explanation / Possible Cause	
60	Current feedback into the inverter is detected.	<ol style="list-style-type: none"> Restart the inverter. Check if phase (L) and neutral (N) cables are not connected reversely in all inverters. For parallel systems with a single phase, make sure the current sharing cables are connected to all inverters. For 3-phase systems, make sure the sharing cables are inter-connected to the inverters on the same phase, and disconnected from inverters in different phases. If the problem remains, please contact your dealer.
71	The firmware version of each inverter is not the same.	<ol style="list-style-type: none"> Check the version of each inverter via the menu as explained in the inverter manual and make sure the CPU versions are same. If they differ, update all inverter firmware to the same version (contact your dealer). If the problem remains, please contact your dealer.
72	The output current of each inverter is inconsistent.	<ol style="list-style-type: none"> Check if sharing cables are connected well and restart the inverters. If the problem remains, please contact your dealer.

80	CAN data loss	<ol style="list-style-type: none"> 1. Check if communication cables are correctly connected and restart the inverters. 2. If the problem remains, please contact your dealer.
81	Host data loss	
82	Synchronisation data loss	
83	The battery voltage of each inverter is inconsistent.	<ol style="list-style-type: none"> 1. Make sure all inverters share the same battery. 2. Remove all AC loads and disconnect the AC input and PV input. Then, check battery voltage on the display of all inverters. If the values from all inverters are close, please check if all battery cables are the same length, diameter and material type. Also check that the battery connection terminals are well secured. If the displayed voltages differ significantly, please contact your dealer. 3. If the problem remains, please contact your dealer.
84	AC input voltage and frequency detected are inconsistent.	<ol style="list-style-type: none"> 1. Check the AC input wiring connection and then restart the inverters. 2. Make sure all phases of the AC input start up at same time. Ensure all AC input breakers can be turned on at same time. 3. If the problem remains, please contact your dealer.
85	AC output current unbalanced.	<ol style="list-style-type: none"> 1. Restart the inverters. 2. Make sure the current sharing cables are correctly connected. 3. Remove some excessive loads and re-check load information from LCD of inverters. If the values are different between the inverters on the same phase, please check if AC input and output cables are the same length, diameter and material type. Make sure the AC terminals are well secured. 4. If the problem remains, please contact your dealer.
86	AC output mode setting is different.	<ol style="list-style-type: none"> 1. For 3-phase systems: check the setting in program 28 (see chapter "Configuration"). Make sure each inverter on the same phase has the same setting (either "L1 phase", "L2 phase" or "L3 phase", no inverter may have the setting "Parallel"). For single phase systems: check the setting in program 28 (see chapter "Configuration"). Make sure each inverter the same "Parallel" setting. 2. If the problem remains, please contact your dealer.

Guarantee Conditions

The Steca guarantee conditions are available on the Internet at:

www.steca.com/pv-off-grid/warranties

Exclusion of Liability

The manufacturer can neither monitor the compliance with this manual nor the conditions and methods during the installation, operation, usage and maintenance of the controller. Improper installation of the system may result in damage to property and, as a result, to bodily injury.

Therefore, the manufacturer assumes no responsibility and liability for loss, damage or costs which result from or are in any way related to incorrect installation, improper operation, incorrect execution of installation work and incorrect usage and maintenance.

Similarly, we assume no responsibility for patent right or other right infringements of third parties caused by usage of this controller. The manufacturer reserves the right to make changes to the product, technical data or installation and operating instructions without prior notice.

Contact

In the case of complaints or faults, please contact the local dealer from whom you purchased the product. They will help you with any issues you may have.

Steca Elektronik GmbH
Mammostrasse 1
87700 Memmingen
Germany

Phone +49 (0) 8331 8558 833
Fax +49 (0) 8331 8558 132

E-mail service@stecasolar.com
Internet www.steca.com